

Part Number: PT278-35140

Kit Contents

Item #	Quantity Req'd.	Description
1	1	LH Base Rail Assembly w/ Crossbar
2	1	RH Base Rail Assembly
3	1	Hardware Bag
4	2	Brackets
5	1	Front Crossbar Assembly

Hardware Bag Contents

Item #	Quantity Req'd.	Description
1	4	M6 x 15.7mm Wafer Head Screws
2	6	M6 x 40mm Button Head Screws
3	1	Operator Caution Card
4	1	M6 Pivot Hinge Screw
5	10	Foam Washers
6	4	M6 x 19.7mm Button Head Screws

Additional Items Required For Installation

Item #	Quantity Req'd.	Description

Conflicts

--

General Applicability

All D-Cab Tacoma Models

Recommended Tools

Personal & Vehicle Protection	Notes
Safety Goggles	
Wrist & Belt Buckle Protectors	
Blankets	
Special Tools	Notes
Installation Tools	Notes
T25 & T30 Torx Driver (Hardened)	i.e.; WihaTools.com, Snap-on, Mac...
Torque Wrench	0-150 lbf-in
Awl	
Nylon Panel Removal Tool	e.g. Panel Pry Tool #1 Toyota SST# 00002-06001-01
Extension	3"
X-Acto Knife, Deburring Tool or equivalent	
Special Chemicals	Notes
None	

Recommended Sequence of Application







Item #	Accessory

*Mandatory

Vehicle Service Parts (may be required for reassembly)

Item #	Quantity Req'd.	Description

Legend

	STOP: Damage to the vehicle may occur. Do not proceed until process has been complied with.
	OPERATOR SAFETY: Use caution to avoid risk of injury.
	CAUTION: A process that must be carefully observed in order to reduce the risk of damage to the accessory/vehicle and to ensure a quality installation.
	TOOLS & EQUIPMENT: Used in Figures calls out the specific tools and equipment recommended for this process.
	REVISION MARK: This mark highlights a change in installation with respect to previous issue.
	SAFETY TORQUE: This mark indicates that torque is related to safety.

Care must be taken when installing this accessory to ensure damage does not occur to the vehicle. The installation of this accessory should follow approved guidelines to ensure a quality installation.

These guidelines can be found in the "Accessory Installation Practices" document.

This document covers such items as:-



- Vehicle Protection (use of covers and blankets, cleaning chemicals, etc.).
- Safety (eye protection, rechecking torque procedure, etc.).
- Vehicle Disassembly/Reassembly (panel removal, part storage, etc.).
- Electrical Component Disassembly/Reassembly (battery disconnection, connector removal, etc.).

Please see your Toyota dealer for a copy of this document.

1. Remove the Ditch Moldings.

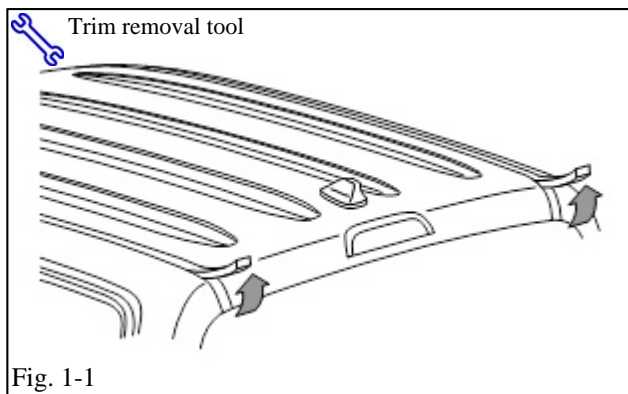
- (a) Pull back the WrapGuard about 10” from each side and cut off the excess (if applicable). Add vehicle protection to the top of the doors and down the side of the vehicle.



-  (b) Carefully remove the ditch moldings from both sides of the vehicle (Fig. 1-1).
- (c) Discard the roof ditch moldings.
-  (d) Carefully remove any remaining tape residue at the rear of the ditch above the rear window.

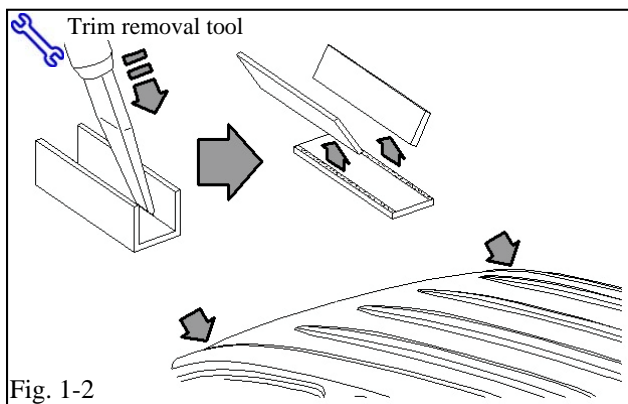

- (e) Use a trim removal tool to break off the vertical walls of the front ditch clips (RH & LH). Wedge the trim removal tool in from the outside then give it a sharp blow with your hand. This should cause the wall to break. Repeat for both sides (Fig. 1-2).

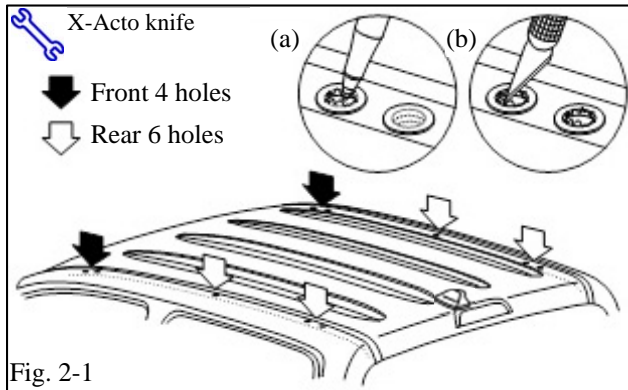

Fig. 2-1

2. Prepare the Roof for Rack Installation.

- (a) Use a finger to locate the tape that covers the 10 weld nuts (5 LH & 5 RH) and press down to create a dimple at each location (Fig. 2-1).

- +** (b) Use an X-Acto knife or deburring tool to carefully remove all seal material in the FRONT 4 HOLES ONLY (2 RH & 2 LH) to expose the weld nut (Fig. 2-1). Ensure no seal material is in the cavity near the threads.

3. Install the RH & LH Side Roof Rack Brackets.

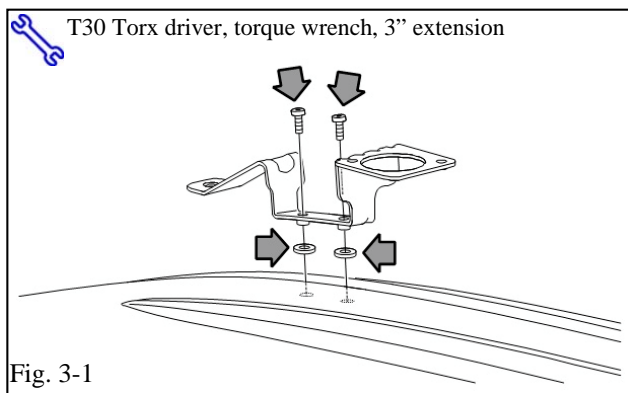

Fig. 3-1

- (a) Remove the adhesive backing & install washers on the bottom of the bracket holes (Fig. 3-1).

- (b) Install the bracket as shown (Fig. 3-1).

- !** (c) Install two M6 x 19.7mm short button head screws (with the pink thread lock); tighten to 13.3 N.m (117.7 lbf-in) (Fig. 3-1).

S Torque: 13.3 N.m (117.7 lbf-in)

- +** (d) Use an X-Acto knife or deburring tool to carefully remove all seal material in the REAR 6 HOLES (3 RH & 3 LH) to expose the weld nut (Fig. 3-2). Ensure no seal material is in the cavity near the threads.

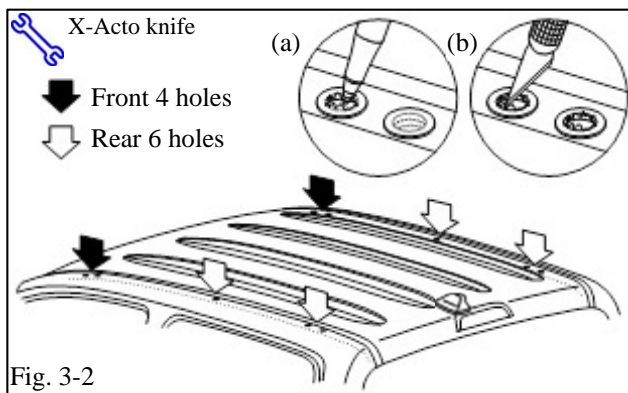
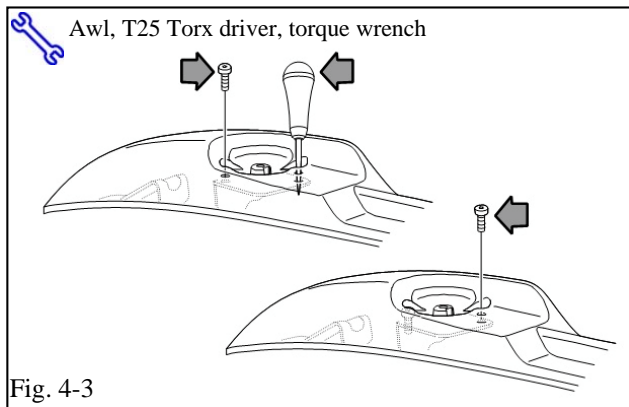
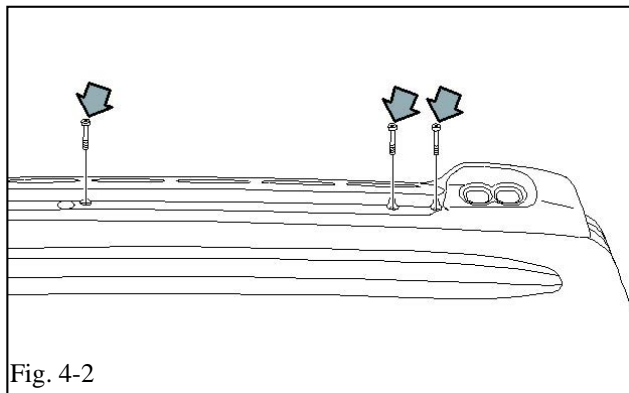
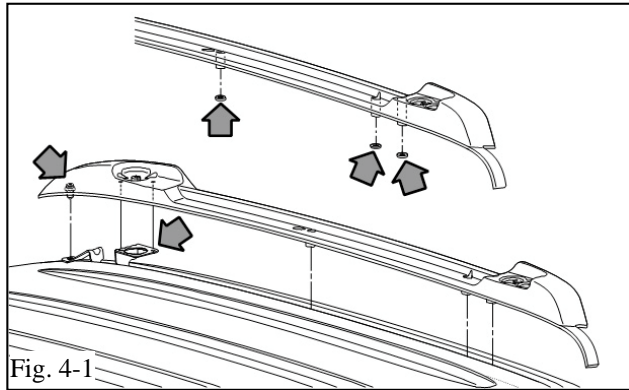

Fig. 3-2



4. Install the RH Side Roof Rack.

- (a) The RH side roof rack does not have the crossbar pre-assembled. Remove the adhesive backing and install 3 washers onto the bottom surface mounting posts, then place it on the roof (Fig. 4-1).
- (b) Align the assembly so that the pad nose fits into the ditch and is snug against the front window lace (Fig. 4-1).
- (c) Visually align the yellow clip at the front above the hole in the bracket. Use the palm of your hand and strike it firmly to seat it in place (Fig. 4-1).
- (d) Hand start the three M6 x 40mm long button head screws (with the blue thread lock) into the roof rack along the roof ditch (Fig. 4-2).

⚠ NOTE: Do not tighten them at this time.

- ⚠** (e) Use an awl to center the bracket hole below the access hole in the roof rail.
 - (1) Install the first M6 x 15.7 mm wafer head screw (with the blue thread lock) and tighten it to ensure that the part does not move when the awl is removed.
 - (2) Install the second wafer head screw and tighten it.
 - (3) Torque the two short wafer head screws to 5.6 N-m (50 lbf-in) (Fig. 4-3).

⚠ Torque: 5.6 N-m (50 lbf-in)

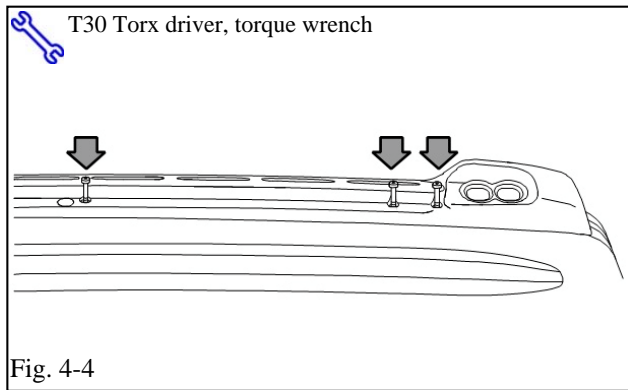

! (f) Torque the three long button head screws to 13.3 N-m (117.7 lbf-in) (Fig. 4-4).

S Torque: 13.3 N-m (117.7 lbf-in)

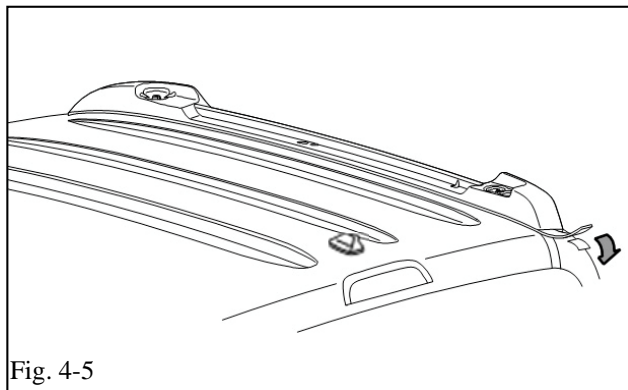

(g) Align the stub on the rear of the pad with the roof ditch. Once aligned, remove the tape backing and press down firmly. Tuck the stub under the rear window lace (Fig. 4-5).

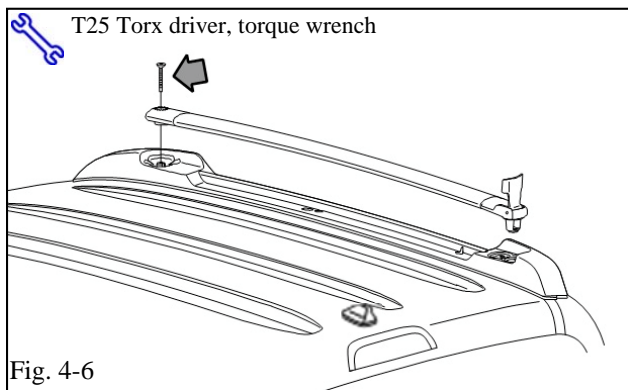

(h) Install the crossbar assembly to the roof rack (Fig. 4-6).

! (i) Install the Torx head pivot bolt and torque it to 5.6 N-m (50 lbf-in) (Fig. 4-6).

S Torque: 5.6 N-m (50 lbf-in)

STOP CAUTION: Be careful NOT to apply too much downward force while torquing the screw as you may push the tap plate out of the holder in the rail below (Fig 4-6).

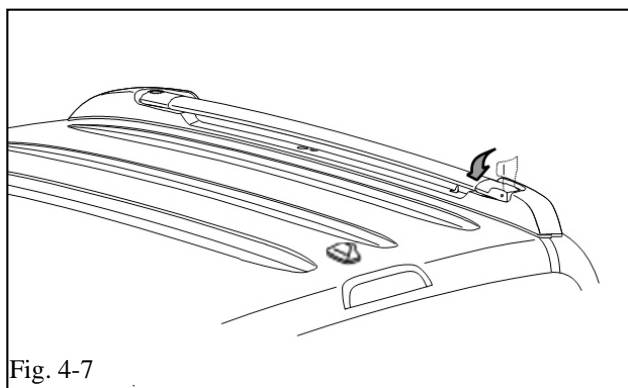

STOP (j) Ensure the crossbar is secure by lowering the lever (Fig. 4-7).

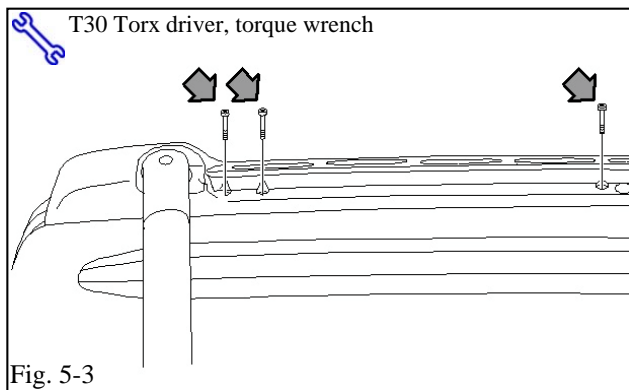
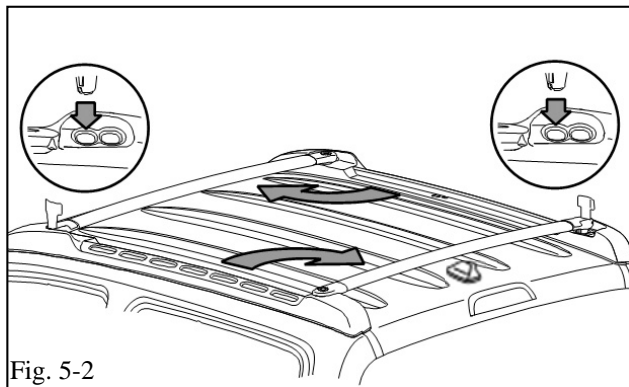
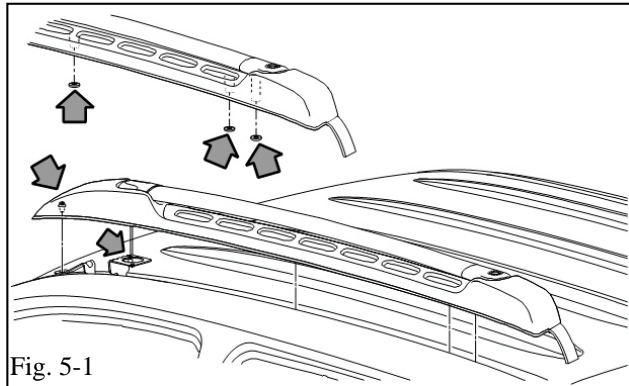

5. Install the LH Side Roof Rack.

- (a) The LH side roof rack has the crossbar preassembled. Remove the adhesive backing and install 3 washers onto the bottom surface mounting posts, then place it on the roof (Fig. 5-1).
 - (b) Align the assembly so that the pad nose fits into the ditch and snug against the front window lace (Fig. 5-1).
 - (c) Visually align the yellow clip at the front above the hole in the bracket. Use the palm of your hand and strike it firmly to seat it in place (Fig. 5-1).
 - (d) Lift the LH & RH crossbar levers into the open position and rotate the crossbars so they rest on the base rails as shown. Do not latch them at this time (Fig. 5-2).
 - (e) Hand start the three long button head screws (with the blue thread lock) into the roof rack along the roof ditch (Fig. 5-3).
- ⚠ NOTE: Do not tighten them at this time.**
- (f) Rotate the crossbar from the LH front rail to access the front screw holes.

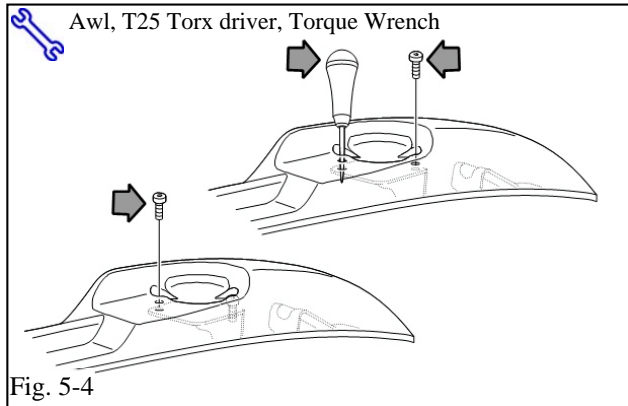

- ⚠ (g) Use an awl to center the bracket hole below the access hole in the roof rail.
 - (1) Install the first M6 x 15.7 mm wafer head screw (with the blue thread lock) and tighten it to ensure that the part does not move when the awl is removed.
 - (2) Install the second wafer head screw and tighten it.
 - (3) Torque the two short wafer head screws to 5.6 N·m (50 lbf·in) (Fig. 5-4).

⚠ **Torque: 5.6 N·m (50 lbf·in)**

- ⚠ (h) Torque the three long button head screws into the roof rack along roof ditch to 13.3 N·m (117.7 lbf·in) (See Fig. 5-3).

⚠ **Torque: 13.3 N·m (117.7 lbf·in)**

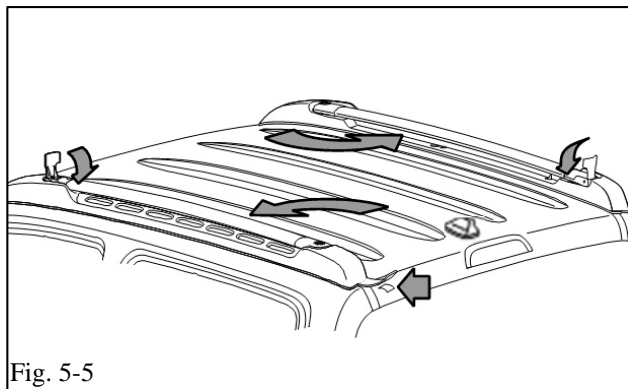

- (i) Align the stub on the rear of the pad with the roof ditch. Once aligned, remove the tape backing and press down firmly. Tuck the stub under the rear window lace (Fig. 5-5).
- (j) Reposition the crossbars into the base rails and close the levers as shown. Ensure the latch is engaged by pulling up on the crossbar above the latch (Fig. 5-5).
- ⚠ (k) Place the 3"x5" roof rack caution card into the owner's manual.

Checklist - these points **MUST** be checked to ensure a quality installation.

<u>Check:</u>	<u>Look For:</u>
<p><u>Accessory Function Checks</u></p> <ul style="list-style-type: none"><input type="checkbox"/> Ensure crossbars will install and lock into the deployed (cross-car) position<input type="checkbox"/> Crossbars should be securely locked into base rails (stowed) for shipment<input type="checkbox"/> Gap between roof rack side rail pads and vehicle roof surface	<p>Crossbars to lock into the deployed (cross-car) position securely</p> <p>Crossbars securely locked into base rails (stowed)</p> <p>Not greater than 1.5 mm</p>
<p><u>Vehicle Function Checks</u></p> <ul style="list-style-type: none"><input type="checkbox"/> None Required	
<p><u>Vehicle Appearance Check</u></p> <ul style="list-style-type: none"><input type="checkbox"/> After accessory installation and removal of protective cover(s), perform a visual inspection.	<p>Ensure no damage (including scuffs and scratches) was caused during the installation process.</p>